



HISTORY

Topstar is a well-established industrial company with a solid presence of over thirty years. Topstar excels in the manufacturing of worktops and components in laminate and compact materials for the furniture industry. Anchored in the dynamic industrial district of the Marche region, our company draws strength from the successful combination of a strong history and a progressive vision. This unique alliance between tradition and innovation guides Topstar through every challenge, whether in terms of production or trade. We are firmly committed to achieving exceptional levels of performance, embodying our dedication to excellence while staying at the forefront of industry developments.

OUR FLEXIBILITY IS LIMITLESS:

We have the capacity to meet your needs, whether for small, medium, or large productions, offering total flexibility to adapt to your specific requirements.

CUSTOM VARIETIES:

We provide the opportunity to supply specific decors, both in Italy and abroad, to meet your unique demands and create customized solutions that transcend borders.

INNOVATION AND SUSTAINABILITY:

Our extensive availability of modern raw materials, coupled with constant technological research, illustrates our commitment to environmental sustainability. Our low formaldehyde emission particle boards and polyurethane adhesive edges demonstrate our ongoing concern to combine innovation with environmental responsibility.

QUALITY IN CONSTANT EVOLUTION:

Topstar is dedicated to continuous improvement of its operational system to guarantee a level of performance that meets the high expectations of the most demanding European customers. Our constant commitment to excellence ensures maximum customer satisfaction.





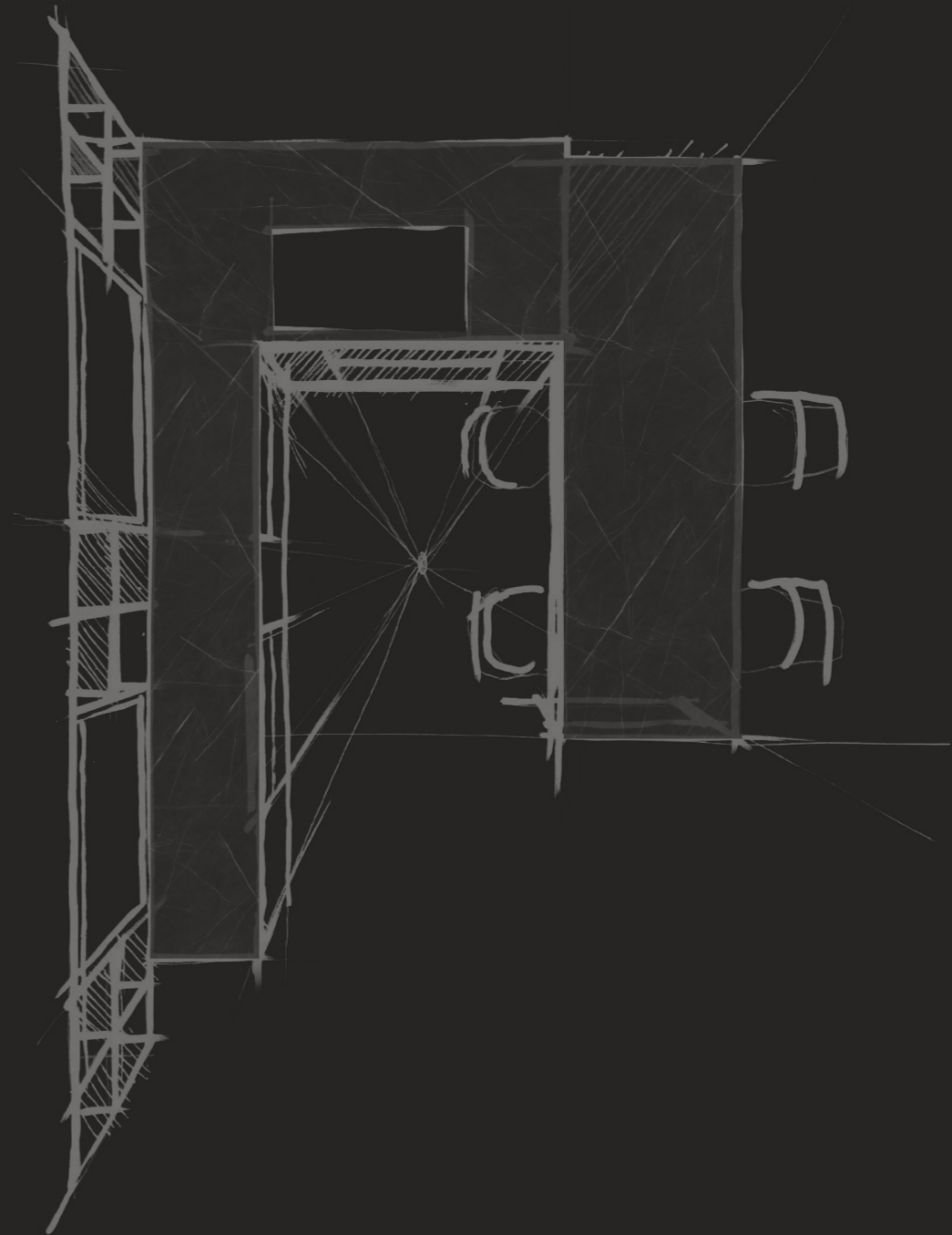



History	Pag. 3
Compact	Pag. 6
Laminated/ Compact Selection	Pag. 12
Worktop Price List	Pag. 24
Backsplash Price List	Pag. 25
Folding Worktop Price List	Pag. 26
Worktop Junctions	Pag. 28
Worktop Processing	Pag. 29
Peninsula / Side Junction	Pag. 32
Backsplash Processing	Pag. 32
Peninsula / Side Junction	Pag. 33
Sinks / Washbasins	Pag. 34
Accessories	Pag. 40
Hardware	Pag. 42
Technical Information	Pag. 44
General Sales Conditions	Pag. 66



	COLOUR	G	CORE	FAMILY
COMPACT	ASD 3166 KINSALE OAK ALBERO 	ZERO	CN	WOOD
	ABET 0421 NERO CLIMB 	1	CN	UNIT TINT
	ARPA 0001 BIANCO CERA 	1	CN	UNIT TINT
		3	CB	
	ARPA 3475 CEPP LUNA 	1	CN	FANTASY
		3	CA	
	ABET 0669 ROVERE PRIMITIVO ROOT 	1	CN	WOOD
	ABET 1972 CORTINA CLASSIC ROOT 	1	CA	WOOD
	ARPA 4538 OLMO BIANCO ALEVÉ 	1	CN	WOOD
	ARPA 4539 OLMO MERCURIO ALEVÉ 	1	CN	WOOD
ARPA 4587 ROVERE SLAVONIA ALEVÉ 	1	CN	WOOD	
ARPA 4625 NOCE SINFONIA ALEVÉ 	1	CN	WOOD	
	3	CA		

	COLOUR	G	CORE	FAMILY
COMPACT	LAMICOLOR 0778 NOCE VINTAGE WOOD 	1	CA	WOOD
	SM'ART C003 POLO CLUB 	1	CN	WOOD
		3	CA	
	SM'ART C005 CRICKET CLUB 	1	CN	WOOD
	ABET 0545 I FINITI CLIMB 	1	CN	STONE
	ABET 0547 TIVOLI GREIGE CLIMB 	1	CN	STONE
		3	CA	
	ABET 1455 ARDESIA CLIMB 	1	CN	STONE
	ABET 1474 GOLDEN MOON GEO 	3	CA	STONE
	ARPA 3276 FIRECOAT FLATTING 	1	CN	STONE
	ARPA 3279 VOLCANIC ASH CIFF 	1	CN	STONE
	ARPA 3366 LUSERNA NERO LUNA NEW 	1	CN	STONE







	COLOUR	G	CORE	FAMILY
COMPACT	ARPA 3410 MUNÉ GREY LOSA  	1	CN	STONE
		3	CA	
	ARPA 3420 CALIPSO LOSA  	1	CN	STONE
	ARPA 3449 YULE WHITE KER  	1	CN	STONE
			3	
	ARPA 3451 KANDIA WHITE KER  	1	CN	STONE
			3	
	ARPA 3476 MARMO ELITE KER  	1	CN	STONE
	LAMICOLOR 5547 STATUARIO SHIKI   SMOOTH	3	CB	STONE
	LAMICOLOR 6074 OROBICO PLAMKY  	1	CN	STONE
	LAMICOLOR 6075 PALLADIO PLAMKY  	1	CN	STONE
			3	
	LAMICOLOR 6087 OLYMPO VELVET2  	1	CN	STONE
		3	CA	
PURICELLI 6019 MARMO BIANCO GHOST  	3	CB	STONE	

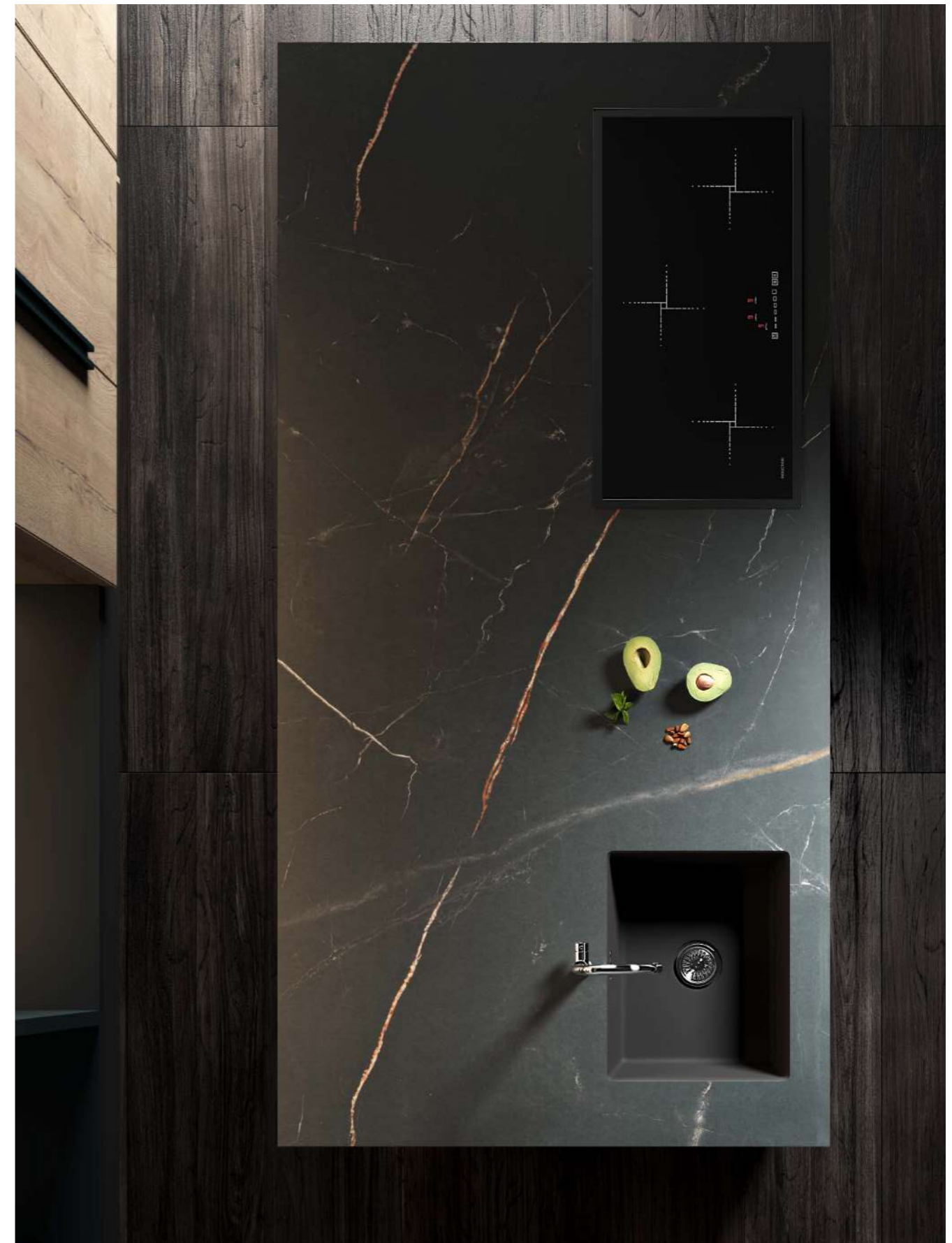

















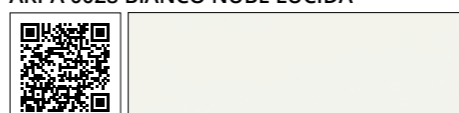

	COLOUR	G	CORE	FAMILY
COMPACT	ARPA 0030 BIANCO ALASKA FENIX NTM  	4	CB	FENIX
	ARPA 0032 BIANCO KOS FENIX NTM  	4	CB	FENIX
	ARPA 0717 CASTORO OTTAWA FENIX NTM  	2	CN	FENIX
	ARPA 0718 GRIGIO LONDRA FENIX NTM  	2	CN	FENIX
	ARPA 0720 NERO INGO FENIX NTM  	2	CN	FENIX
	ARPA 0749 CACAO ORINOCO FENIX NTM  	2	CN	FENIX
	ARPA 0750 VERDE COMODORO FENIX NTM  	2	CN	FENIX
	ARPA 0751 ROSSO JAPUR FENIX NTM  	2	CN	FENIX
	ARPA 0754 BLU FES FENIX NTM  	2	CN	FENIX
	ARPA 2630 PIOMBO DOHA FENIX NTM  	2	CN	FENIX

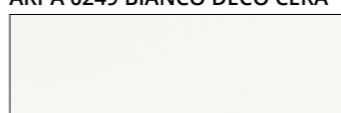
COMPACT 12 MM

	COLOUR	G	CORE	FAMILY
COMPACT	ARPA 2638 TITANIO DOHA FENIX NTM 	2	CN	FENIX
	COMING SOON			
	COMING SOON			
	COMING SOON			
	COMING SOON			
	COMING SOON			
	COMING SOON			
	COMING SOON			
	COMING SOON			
	COMING SOON			

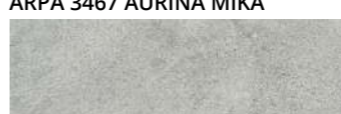













	COLOUR	THICKNESS			G	TH	G	C	FAMILY	
		19 mm	39 mm	59 mm						
GROUP ZERO	ASD 3166 KINSALE OAK ALBERO  	●	●	●	GROUP ZERO	●	ZERO	CN	LEGNO	
	PURICELLI 5501 NOCE CANALETTO AR  	●	●							LEGNO
	PURICELLI 6019 MARMO BIANCO AR  	●	●							PIETRE
	PURICELLI 6133 MARMO NERO AR  	●	●							PIETRE
	PURICELLI 6152 BIANCO LASA MN  	●	●							PIETRE
	PURICELLI M510 SATIN TITANIO MA  	●	●							FANTASIA
	SAVIOLA D16 ROVERE RUSTICO ROCK WOOD  	●	●	●						LEGNO
	SAVIOLA 67A COPPERFIELD GRIGIO METAL  	●	●	●						FANTASIA
	SAVIOLA 988 ROVERE NODATO ARTWOOD  	●	●	●						LEGNO
	SAVIOLA T25 GRACE STONE CHIARO TOPMAT  	●	●							PIETRE































	COLOUR	THICKNESS			G	TH	CORE	G
		19 mm	39 mm	59 mm				
FANTASY / UNIT TINT	ABET 0410 BIANCO CLIMB  	●	●	●	1			
	ABET 0421 NERO CLIMB  	●	●		1	●	CN	1
	ABET 0869 GRIGIO ALPACA CLIMB  	●	●		1			
	* ABET 0873 ALLUMINIO SATINATO  				4			
	ARPA 0001 BIANCO CERA  	●	●		2	●	CN	1
							CB	3
	ARPA 0028 BIANCO NUBE LUCIDA  	●	●		2			
	ARPA 0249 BIANCO DECÓ CERA  	●	●		2			
	ARPA 3331 CORTEN GRIGIO FLATTING  	●	●		2			
	ARPA 3467 AURINA MIKA  	●	●		2			
	ARPA 3475 CEPP LUNA  	●	●		2	●	CN	1
							CA	3



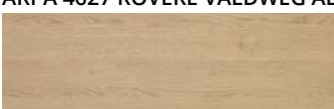



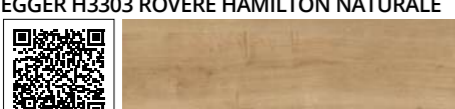











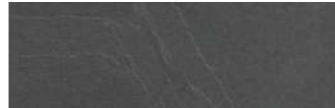



















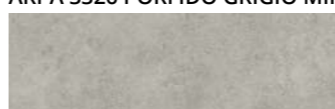



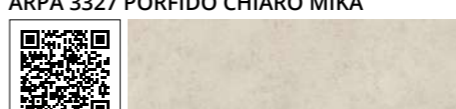

	COLOUR	THICKNESS			G	TH	CORE	G
		19 mm	39 mm	59 mm				
FANTASY / UNIT TINT	ARPA 3480 YARIK KER 	●	●		2			
	CLEAF FA33 MAYA BRONZE PENELOPE 	●	●		1			
	CLEAF FB02 BETON ITALIAN STONE 	●	●		2			
	CLEAF FB11 BETON ITALIANSTONE 	●	●		2			
	CLEAF FB45 AZIMUT ITALIAN STONE 	●	●		2			
	CLEAF FB51 VERTIGO ITALIAN STONE 	●	●		2			
	EGGER F275 CALCESTRUZZO SCURO ST9 	●	●		2			
	EGGER F638 CHROMIX ARGENTO ST9 	●	●		2			
	LAMICOLOR 0751 BIANCO PLAMKY 	●	●		2			
	LAMICOLOR 0934 PELTRO TOUCH FINISH 	●	●		2			

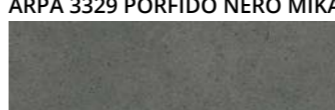



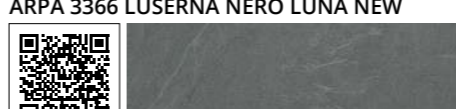















	COLOUR	THICKNESS			G	TH	CORE	G
		19 mm	39 mm	59 mm				
FANTASY / UNIT TINT	LAMICOLOR 1398 GRIGIO PLUTONE PLAMKY 	●	●		2			
	LAMICOLOR 5025 BRASS FLASH 	●	●		2			
	LAMICOLOR 5026 INOX FLASH 	●	●		2			
	LAMICOLOR 5027 FERRO FLASH 	●	●		2			
	RESOPAL 3510 SABBIA F60 	●	●		2			
	ASD 1058 BIANCO SPACE 	●	●		1			
	COMING SOON							
	COMING SOON							
	COMING SOON							
	COMING SOON							

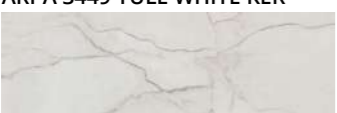







	COLOUR	THICKNESS			G	TH	CORE	G
		19 mm	39 mm	59 mm				
WOOD	ABET 0669 ROVERE PRIMITIVO ROOT 	●	●		2	●	CN	1
	ABET 1972 CORTINA CLASSIC ROOT 	●	●	●	2	●	CA	1
	ARPA 4490 TAVOLATO NERO FLATTING 	●	●	●	2			
	ARPA 4538 OLMO BIANCO ALEVÉ 	●	●		2	●	CN	1
	ARPA 4539 OLMO MERCURIO ALEVÉ 	●	●	●	2	●	CN	1
	ARPA 4584 ROVERE WAFER ALEVÉ 	●	●	●	2			
	ARPA 4587 ROVERE SLAVONIA ALEVÉ 	●	●	●	2	●	CN	1
	ARPA 4604 NOCE SAVOIA ALEVÉ 	●	●		2			
	ARPA 4625 NOCE SINFONIA ALEVÉ 	●	●	●	2	●	CN	1
							CA	3
	ARPA 4631 TAGES ALEVÉ 	●	●		2			

	COLOUR	THICKNESS			G	TH	CORE	G
		19 mm	39 mm	59 mm				
WOOD	CLEAF LR25 ASCARI SABLÉ 	●	●		2			
	CLEAF LR33 ABBEY SABLÉ 	●	●		2			
	CLEAF S073 ROVERE FRASSINO 	●	●	●	2			
	EGGER H1180 ROVERE NATURALE 	●	●	●	2			2 ST10 * 4 ST37
	EGGER H1181 ROVERE TABACCO ST37 	●	●					*4
	EGGER H1322 MATTERHORN CHENE ST12 	●	●					1
	EGGER H3157 ROVERE VICENZA ST12 	●	●	●	2			
	EGGER H2032 MURPHY ST10 	●	●		2			
	KAINDL 34139 ROVERE VOYAGER AT 	●	●		3			
	KAINDL 34217 ROVERE ACTUAL AT 	●	●		3			

	COLOUR	THICKNESS			G	TH	CORE	G
		19 mm	39 mm	59 mm				
WOOD	LAMICOLOR 0778 NOCE VINTAGE WOOD 				2		CA	1
	LAMICOLOR 0803 TAVERN WOOD 				2			
	RESOPAL 4344 RUSTIC OAK WH 				3			
	SM'ART C003 POLO CLUB 				*4		CN	1
							CA	3
	SM'ART C005 CRICKET CLUB 				*4		CN	1
	SM'ART C007 SKI CLUB 				*4			
	ARPA 4627 ROVERE VALDWEG ALEVE 				2			
	EGGER H3303 ROVERE HAMILTON NATURALE 				2			
	SOON							
SOON								

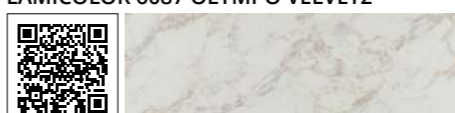
	COLOUR	THICKNESS			G	TH	CORE	G
		19 mm	39 mm	59 mm				
STONE	ABET 0545 I FINTI CLIMB 				1		CN	1
	ABET 0547 TIVOLI GREIGE CLIMB 				1		CN	1
							CA	3
	ABET 1455 ARDESIA CLIMB 				1		CN	1
	ABET 1474 GOLDEN MOON GEO 				1		CA	3
	ARPA 3276 FIRECOAT FLATTING 				2		CN	1
	ARPA 3279 VOLCANIC ASH CIFF 				2		CN	1
	ARPA 3326 PORFIDO GRIGIO MIKA 				2			
	ARPA 3327 PORFIDO CHIARO MIKA 				2			
	ARPA 3329 PORFIDO NERO MIKA 				2			
	ARPA 3366 LUSERNA NERO LUNA NEW 				2		CN	1

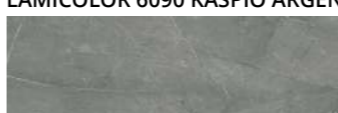
	COLOUR	THICKNESS			G	TH	CORE	G
		19 mm	39 mm	59 mm				
STONE	ARPA 3410 MUNÉ GREY LOSA  	●	●	●	3	●	CN	1
							CA	3
	ARPA 3412 VOYAGE BRONZE URBAN  	●	●	●	2			
	ARPA 3413 VOYAGE SILVER URBAN  	●	●	●	2			
	ARPA 3420 CALIPSO LOSA  	●	●	●	3	●	CN	1
	ARPA 3446 PULPIS DARK KER  	●	●		3			
	ARPA 3447 PULPIS LIGHT KER  	●	●		3			
	ARPA 3449 YULE WHITE KER  	●	●		3	●	CN	1
							CA	3
	ARPA 3451 KANDIA WHITE KER  	●	●		3	●	CN	1
				CA			3	
ARPA 3457 ROX BLACK KER  	●	●		3				
ARPA 3476 MARMO ELITE KER  	●	●	●	3	●	CN	1	

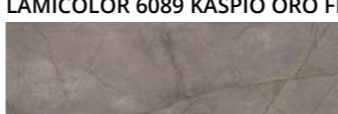
	COLOUR	THICKNESS			G	TH	CORE	G
		19 mm	39 mm	59 mm				
STONE	LAMICOLOR 5547 STATUARIO SHIKI   SMOOTH	●	●		2	●	CB	3
	LAMICOLOR 5547 STATUARIO PLAMKY   ROUGH	●	●		2			
	LAMICOLOR 5563 ORIENTAL PLAMKY  	●	●		3			
	LAMICOLOR 6074 OROBICO PLAMKY  	●	●	●	2	●	CN	1
	LAMICOLOR 6075 PALLADIO PLAMKY  	●	●	●	2	●	CN	1
								CA
	LAMICOLOR 6087 OLYMPO VELVET2  	●	●		2	●	CN	1
								CA
LAMICOLOR 6090 KASPIO ARGENTO FLASH  	●	●		2				
PURICELLI 6019 MARMO BIANCO GHOST  					●	CB	3	
LAMICOLOR 6089 KASPIO ORO FLASH  	●	●	●	2				
	COMING SOON							



FENIX	COLOUR	THICKNESS			G	TH	CORE	G
		19 mm	39 mm	59 mm				
	ARPA 0029 BIANCO MALÉ FENIX NTM 	●	●		4			
	ARPA 0030 BIANCO ALASKA FENIX NTM 	●	●		4	●	CB	4
	ARPA 0032 BIANCO KOS FENIX NTM 	●	●	●	4	●	CB	4
5								
	ARPA 0717 CASTORO OTTAWA FENIX NTM 	●	●		4	●	CN	2
	ARPA 0718 GRIGIO LONDRA FENIX NTM 	●	●		4	●	CN	2
5								
	ARPA 0720 NERO INGO FENIX NTM 	●	●		4	●	CN	2
5								
	ARPA 0724 GRIGIO BROMO FENIX NTM 	●	●		4			
5								
	ARPA 0725 GRIGIO EFESO FENIX NTM 	●	●		4			
	ARPA 0748 BEIGE ARIZONA FENIX NTM 	●	●		4			
	ARPA 0749 CACAO ORINOCO FENIX NTM 	●	●	●	4	●	CN	2
5								

FENIX	COLOUR	THICKNESS			G	TH	CORE	G
		19 mm	39 mm	59 mm				
	ARPA 0750 VERDE COMODORO FENIX NTM 	●	●	●	4	●	CN	2
5								
	ARPA 0751 ROSSO JAPUR FENIX NTM 	●	●	●	4	●	CN	2
5								
	ARPA 0752 GRIGIO ANTRIM FENIX NTM 	●	●		4			
	ARPA 0754 BLU FES FENIX NTM 	●	●		4	●	CN	2
5								
	ARPA 2628 ZINCO DOHA FENIX NTM 	●	●		4			
	ARPA 2629 BRONZO DOHA FENIX NTM 	●	●	●	4			
	ARPA 2630 PIOMBO DOHA FENIX NTM 	●	●		4	●	CN	2
	ARPA 2638 TITANIO DOHA FENIX NTM 	●	●	●	4	●	CN	2
	COMING SOON							
	COMING SOON							

PRICE LIST WORKTOPS

Useful size 4150 mm x 1280 mm ABS
edge front included (excluding compact)

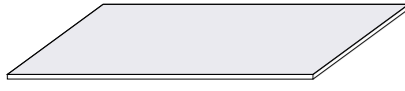

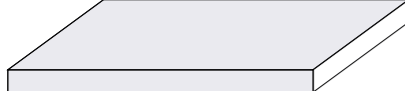

THICKNESS 12 MM COMPACT	REF.	DEPTH	
GROUP			
 <p>ALWAYS DOUBLE-SIDED 4-EDGED BRUSHED</p>	PTC40	240 - 400	
	PTC64	401 - 640	
	PTC78	641 - 780	
	PTC90	781 - 900	
	PTC128	901 - 1280	
* THICKNESS 19 MM LAMINATE	REF.	DEPTH	
GROUP			
	PT40-19	0 - 400	
	PT65-19	401 - 650	
	PT90-19	651 - 900	
	PT120-19	901 - 1200	
	PT128-19	1201 - 1280	
* THICKNESS 39 MM LAMINATE	REF.	DEPTH	
GROUP			
	PT40-39	0 - 400	
	PT65-39	401 - 650	
	PT90-39	651 - 900	
	PT120-39	901 - 1200	
	PT128-39	1201 - 1280	
* THICKNESS 59 MM LAMINATE	REF.	DEPTH	
GROUP			
	PT40-59	0 - 400	
	PT65-59	401 - 650	
	PT90-59	651 - 900	
	PT120-59	901 - 1200	
	PT128-59	1201 - 1280	

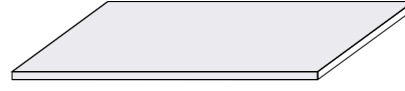
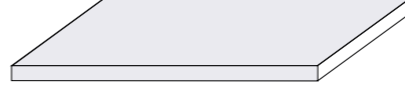
* LAMINATED 2 SIDES EXTRA CHARGE + 35% (ABS EDGE FRONT AND BACK INCLUDED)

THICKNESS 19 MM LAMINATE	REF.	DEPTH	
GROUP			
 <p>LAMINATE FENIX FULL COLOR 1,2 mm</p>	PTCI64-19	600 - 640	
	PTCI80-19	641 - 800	
	PTCI128-19	801 - 1280	
THICKNESS 39 MM LAMINATE	REF.	DEPTH	
GROUP			
 <p>LAMINATE FENIX FULL COLOR 1,2 mm</p>	PTCI64-19	600 - 640	
	PTCI80-19	641 - 800	
	PTCI128-19	801 - 1280	

PRICE LIST SIDE PANELS

THICKNESS 12 MM COMPACT	REF.	DEPTH	
GROUP			
	PCC24	50 - 240	
	PCC30	241 - 300	
	PCC40	301 - 400	
	PCC64	401 - 640	
	PCC78	641 - 780	
	PCC90	781 - 900	
	PCC128	901 - 1280	
* THICKNESS 13 MM LAMINATE	REF.	DESCRIPTION	
GROUP			
	PR1-13	1 DECORATIVE SIDE + 4 ABS EDGES	

* LAMINATED 2 SIDES EXTRA CHARGE + 35%

MINIMAL INVOICE 0,30 m²

A

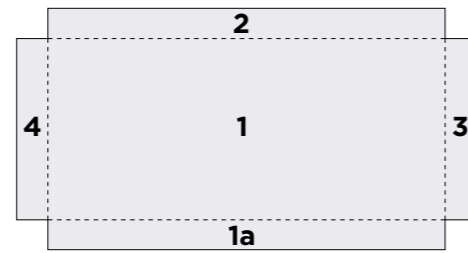
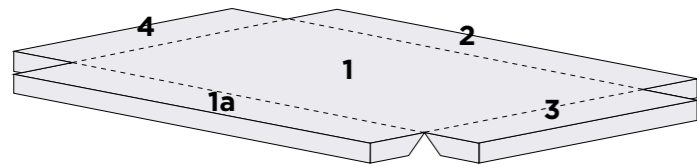

B

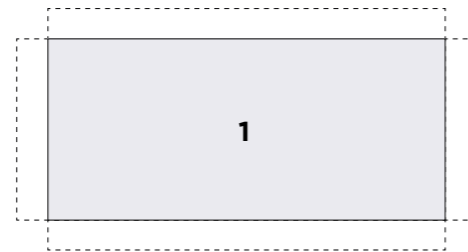
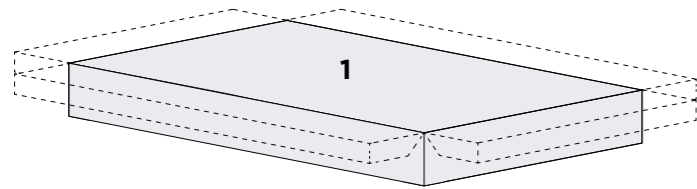

C

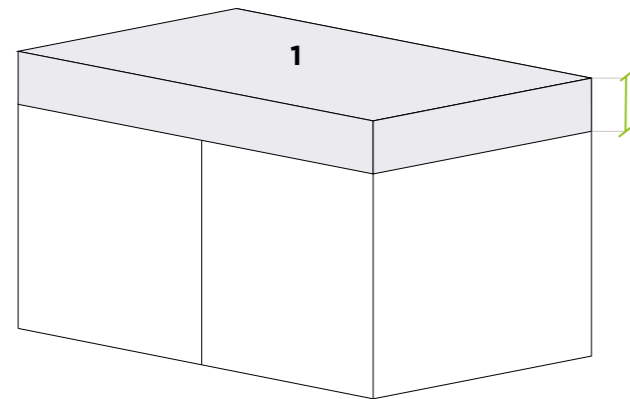

Minimum and maximum size of the veil:
From 20 mm to 120 mm

DEPTH/LENGTH CALCULATION FORMULA

DEPTH: (P1 + P1a) + P2 optional → ES.: 640(P1) + 80(P1a) + 80(P2) = 800 mm
 LONGITUDE: L1 + L3 optional + L4 optional → ES.: 2000(L1) + 80(L3) + 80(L4) = 2160 mm

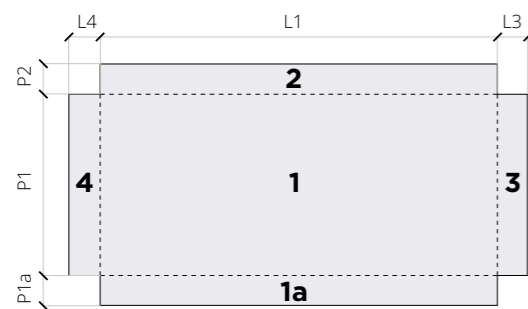

▲ WARNING:

The total dimensions of P1a + P1 + P2 must never exceed 1280 mm
 The total dimensions of L4 + L1 + L3 must never exceed 4150 mm.







THICKNESS 12 MM COMPACT	REF.	DEPTH	
GROUP			
	PTCF40	240 - 400	
	PTCF64	401 - 640	
	PTCF78	641 - 780	
	PTCF90	781 - 900	
	PTCF128	901 - 1280	
THICKNESS 19 MM LAMINATE	REF.	DEPTH	
GROUP			
	PTF40-19	0 - 400	
	PTF65-19	401 - 650	
	PTF90-19	651 - 900	
	PTF120-19	901 - 1200	
	PTF128-19	1201 - 1280	
THICKNESS 19 MM LAMINATE	REF.	DEPTH	
GROUP			
 LAMINATE FENIX FULL COLOR 1,2 mm	PTCI64-19	600 - 640	
	PTCI80-19	641 - 800	
	PTCI128-19	801 - 1280	

SPECIAL PACKAGING	REF.	DEPTH	
 WOODEN STRUCTURE	EMSPPTCI	0 - 1280	

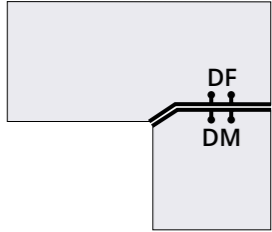

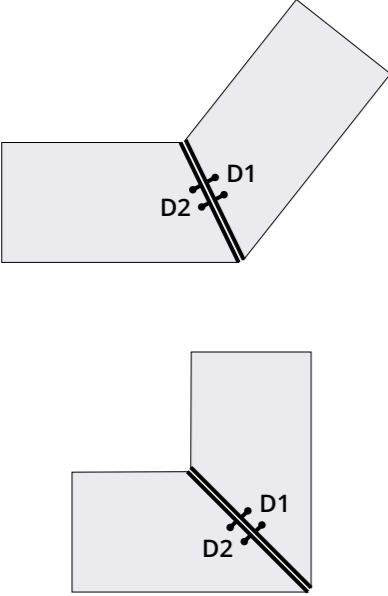

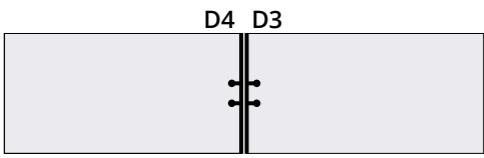
COMPATIBLE PROCESSING WITH FOLDING SIDES: DF, DM, D1, D2, D3, D4, XA, XB, XC, XD

MAXIMUM PANEL DIMENSIONS INCLUDING MACHININGS: 4150 X 1280 mm

WORKTOP JOINTS

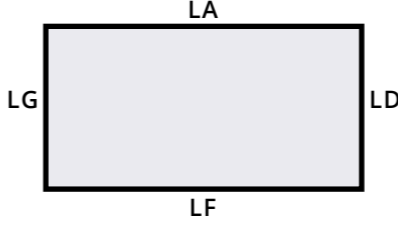
MALE - FEMALE	REF.	DESCRIPTION	U.M.	P. COMPACT	P. LAMINATE
	DF	FEMALE CUT	Unit		
	DM	MALE CUT	Unit		
	Ironry included Laminata:  Compact: 				
ANGLE	REF.	DESCRIPTION	U.M.	P. COMPACT	P. LAMINATE
	D1	INCLINED ANGLE	Unit		
	D2	45° ANGLE	Unit		
	Ironry included Laminata:  Compact: 				
LINEAR	REF.	DESCRIPTION	U.M.	P. COMPACT	P. LAMINATE
	D3	LINEAR	Unit		
	D4	LINEAR	Unit		
	Ironry included Laminata:  Compact: 				







WORKTOPS PROCESSING

ABS EDGE	REF.	DESCRIPTION	U.M.	P. COMPACT	P. LAMINATE
	LD	ABS RIGHT EDGE	Unit		
	LG	ABS LEFT EDGE	Unit		
	LA	ABS BACK EDGE	m/l		
	LF	ABS FRONT EDGE	m/l		Inclusa
CHAMFERED CORNERS	REF.	DESCRIPTION	U.M.	P. COMPACT	P. LAMINATE
	XA	RIGHT FRONT CHAMFER	Unit		
	XB	RIGHT BACK CHAMFER	Unit		
	XC	LEFT FRONT CHAMFER	Unit		
	XD	RIGHT BACK CHAMFER	Unit		
ROUNDED EDGE	REF.	DESCRIPTION	U.M.	P. COMPACT	P. LAMINATE
 <p>LAMINATE: RAY MIN. 30 mm COMPACT: RAY MIN. 10 mm</p>	FA	ROUNDED RIGHT FRONTSIDE	Unit		
	FB	ROUNDED RIGHT BACKSIDE	Unit		
	FC	ROUNDED LEFT FRONTSIDE	Unit		
	FD	ROUNDED LEFT BACKSIDE	Unit		
90° PILLAR CUTOUT+ ABS	REF.	DESCRIPTION	U.M.	P. COMPACT	P. LAMINATE
	DP90°	90° PILLAR CUTOUT+ ABS	Unit	/	

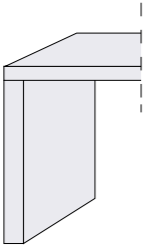
SPECIAL SHAPE + ABS	REF.	DESCRIPTION	U.M.	P. COMPACT	P. LAMINATE
	DSFL	EDGED SPECIAL SHAPE + ABS	Unit		
ARCHED EDGED PENINSULA + ABS	REF.	DESCRIPTION	U.M.	P. COMPACT	P. LAMINATE
	FG	ARCHED EDGED PENINSULA + ABS	Unit		
CIRCULAR TABLE EDGED + ABS	REF.	DESCRIPTION	U.M.	P. COMPACT	P. LAMINATE
	FH	CIRCULAR TABLE EDGED + ABS	Unit		
TAP HOLE	REF.	DESCRIPTION	U.M.	P. COMPACT	P. LAMINATE
	TRRC	TAP HOLE	Unit		Protective resin included

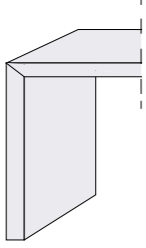
SINK HOLES	REF.	DESCRIPTION	U.M.	P. COMPACT	P. LAMINATE
 DEVPCFC - DEVPC RAY MIN 7,5 mm DEVPOLC RAY MIN 10 mm	DEVPC	HOLE SINK STANDARD	Unit	/	
	DEVPCF	FLUSH SINK HOLE + PROTECTIVE RESIN	Unit	/	
	DEVPC	HOLE SINK STANDARD	Unit		/
	DEVPCFC	SINK HOLE FLUSH TOP	Unit		/
	DEVPOLC	UNDER-TOP SINK HOLE	Unit		/
DRAINER	REF.	DESCRIPTION	U.M.	P. COMPACT	P. LAMINATE
 NOT COMPATIBLE WITH INTEGRATED SINK	DEGEVC	5 MILLINGS FOR DRAINER	Unit		/
PILLAR BURGLARY	REF.	DESCRIPTION	U.M.	P. COMPACT	P. LAMINATE
 DCB DCP R10 DPR	DCB	COARSE EDGE. R10	Unit		/
	DCP	BRUSHED EDGE R10	Unit		/
	DPR	COARSE EDGE. 90°	Unit	/	

HIP JOINTS + PENINSULA

HIP - PENINSULA	REF.	DESCRIPTION	U.M.	COMPACT	LAMINATE	I.INCLUDED
	UJ	3 SIDED ABS EDGE + PROTECTED SIDE + ADJUSTABLE FEET	Unit	/		
HIP - PENINSULA 45°	REF.	DESCRIPTION	U.M.	COMPACT	LAMINATE	I.INCLUDED
	UJ45	3 SIDED ABS EDGE + PROTECTED SIDE + ADJUSTABLE FEET CONSIDER PENINSULA THICKNESS	Unit			 Laminata TH. 20 mm  TH. 40/60 mm  Compact

PENINSULES PROCESSING

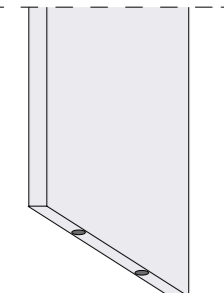
FEET	REF.	DESCRIPTION	U.M.	COMPACT	LAMINATE	I. INCLUDED
	UPS	ADJUSTABLE FEET AVAILABLE ON LAMINATE ONLY				

SIDE PANELS

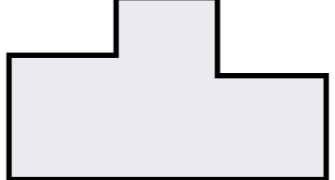
EDGED PILLAR RECESS + ABS	REF.	DESCRIPTION	U.M.
	DSCR	EDGED PILLAR RECESS + ABS	Unit

SHELVES PROCESSING

SHELVES	REF.	DEPHT	QUANTITY	U.M.	I. INCLUDED
 Max. weight 15kg/fixe Shelf depth min 200 max 350 (mm) Shelf thickness 39 and 59 (mm)	USEC	0 - 800	2	Unit	INCLUDED
		801 - 1500	+1	Unit	
		1501 - 2500	+2	Unit	
		2501 - 3500	+3	Unit	
		3501 - 4180	+4	Unit	

IRONMONGERY
* n° 2 

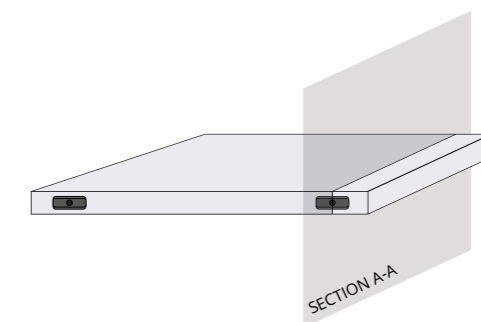

INTEGRATED SINKS

KITCHEN SINKS



EMSPPTCI SPECIAL PACKAGING WITH WOODEN CRATE 77 PTS m/l

Sinks colours	
Fenix	Elleci
0032	0749
0720	0751
0724	0750
0754	
	K96
	KM5
	K86
	Edge sinks

KITCHEN	FENIX	REF.	DIM.
		EVFX50	500X400
		EVFX72	720X400
			

KITCHEN	EDGE SINKS - INOX	REF.	DIM.
		EVINX54	540X400
		EVINX76	760X400

KITCHEN	ELLECI	REF.	DIM.
		EVL40	400X400
		EVL50	500X400
			

BATHROOM WASHBASIN

EMSPPTCI SPECIAL PACKAGING WITH WOODEN CRATE 77 PTS m/l



BATHROOM	ELLECI	REF.	DIM.
		LAVLC48	480X340
		LAVLC64	640X340
			

BATHROOM	FENIX	REF.	DIM.
		LAVFX52	520X340
		LAVFX68	680X340
			

IMPOSSIBLE INTEGRATION WITH SOLID COLOURS AND ZERO GROUP LAMINATES

TOPSTAR KITCHEN SINKS IN COMPACT

EMSPPTCI SPECIAL PACKAGING WITH WOODEN CRATE 77 PTS m/l

KITCHEN	SINK COMPACT		REF.	MEASURE
		CCOM40	400X400	
		CCOM54	500X400	
		CCOM70	710X400	
SINK COMPACT + DRAINER		REF.	MEASURE	
GRUPPI				
	CCOM100	1000X400		
	TANK DIMENSIONS: 500x400			

STAINLESS STEEL SINK BOTTOMS

SINK BOTTOM COMPACT	MEASURE	REF.
	400X400	FCCOM
	500X400	
	710X400	

FOSTER STAINLESS STEEL KITCHEN SINKS

KITCHEN	QUADRA 1			KITCHEN	S4001					
	REF.	MEASURE	REF.		MEASURE					
	ECFQ96	960X400			ECFS471	710X400				
	QUADRA 2				REF.			MEASURE		
		ECFQMI71	710X400							
		QUADRA 3			REF.			MEASURE		
	ECFQMI50	500X400								
	QUADRA 4			REF.			MEASURE			
	ECFQ50	500X400								

SINKS FOR FLUSH-MOUNT INSTALLATION ONLY, COMPATIBLE WITH DEVPCF AND DEVPCFC PROCESSES

FOSTER STAINLESS STEEL KITCHEN SINKS



KITCHEN	KE 1	REF.	MEASURE	KITCHEN	MASTER 2BD - 2BG	REF.	MEASURE
		ECFKE71	710X400			ECFMA111	1110X400
KITCHEN	KE 2	REF.	MEASURE	KITCHEN	MASTER BD - BG	REF.	MEASURE
		ECFKE50	500X400			ECFMA815	815X400
KITCHEN	KE 3	REF.	MEASURE				
		ECFKE40	400X400				

SINKS FOR FLUSH-MOUNT INSTALLATION ONLY,
COMPATIBLE WITH DEVPCF AND DEVPCFC PROCESSES

FOSTER KITCHEN FAUCETS



KITCHEN	DELTA EXTRACTABLE	REF.	KITCHEN	DELTA PLUS EXTRACTABLE	REF.
		MICFDE			MICFDEP
KITCHEN	OMEGA	REF.	KITCHEN	OMEGA PLUS	REF.
		MICFOM			MICFOMP
KITCHEN	LORENZO	REF.	KITCHEN	NYC	REF.
		MICFLO			MICFNY
KITCHEN	ARSENIO EXTRACTABLE	REF.	KITCHEN	FLAT EXTRACTABLE	REF.
		MICFAR			MICFFL

ACCESSORIES

LARGE DRAINER	MEASURE	REF.	
	409X417	ACEVG	
			

DRAINER/CUTTER G.	DIM.	REF.	
	409X417	ACEBAG	
			

SMALL DISHES DRAINER MIX	DIM.	REF.	
	417X280	ACEMXP	
			

SMALL DISHES DRAINER	DIM.	REF.	
	417X280	ACEVP	
			

SMALL CUTLERY	DIM.	REF.	
	417X280	ACBAP	
			

SIDE PANELS KIT PROTECTION	DIM.	REF.	
	TH. 20 mm TH. 40 mm	KITSAB	
			

UNIT PRICES

HARDWARE

LAMINATE TOP JOINTS	REF.	
	QASPP	

FLAT JOINTS IN COMPACT	REF.	
	QACPP	

LAMINATE SIDE JOINTS	REF.	
	QASPJ	

ADJUSTABLE FEET	REF.	
	PDSR	

45° COMPACT SIDE JOINTS	REF.	
	QACPJ45	

45° LAMINATE SIDE JOINTS	REF.	
	QASPJ454	
		TH. 40/60 mm

45° LAMINATE SIDE JOINTS	REF.	
	QASPJ452	
		TH. 20 mm

CONCEALED SHELF HARDWARE	REF.	
	SEC	

ABS EDGE	REF.	
	CHABS	

TECHNICAL INFORMATION

COMPACT PANELS



The Compact, available with a thickness of 12 mm, is composed of sheets of paper impregnated with resins and pressed at high pressure. The visible core between its two decorative faces is available in black, white, or matched to the chosen decoration. It can also be coated with a matching ABS edge. Suitable for any work surface and backsplash, the compact ensures optimal maintenance ease thanks to its surface identical to that of an HPL laminate. Its high density gives it exceptional resistance to moisture and impacts. The impalpability resistance feature even allows for the integration of sinks. To absorb potential expansions, it is recommended to leave a space of 3 to 5 mm between the work surface and the wall. Detailed information to simplify installation can be obtained by contacting our sales service upon request.

USE AND TECHNICAL FEATURES

WORKTOP AND SIDES

- Minimum workable size: 240 x 560 mm
- Maximum workable size: 1280 x 4150 mm

WALL PANELS

- Minimum size for 3-sided chamfering: L 560 mm x H 50 mm
- Minimum size for 4-sided chamfering: L 560 mm x H 240 mm
- Minimum size for ABS edge plating: H 80 mm

Chamfering is performed at no extra cost; please indicate it in your drawing.

LAMINATE PANELS

High Pressure Laminate (HPL) panels result from a production process that involves assembling three main elements: the laminate sheet, obtained through the pressing of kraft paper and decorative paper impregnated with resin and coated with a transparent film to protect printed designs. The moisture-resistant chipboard panel offers increased resistance to humidity and optimal durability, with an average density of 535 kg/m³. Lastly, the balancing laminate sheet, white for single-faced panels or matched to the surface for double-faced decorative panels. This configuration makes it an optimal choice for work surfaces, offering significant resistance to normal household activities such as water splashes and food contact. The range of available colors is curated considering the latest trends, with a priority for hues inspired by pure and natural materials like marble, stone, and wood.

USE AND TECHNICAL FEATURES

WORKTOP AND SIDES

- Support: Moisture-resistant chipboard panel thickness 19 - 39 - 59 mm
- Frontal Laminate: Decorative Laminate
- Back Laminate: White Balancing Laminate or Decorative Laminate for double-sided
- Edge: ABS
- Maximum Dimensions: 1280 mm - 4150 mm

WALL PANELS

- Support: Standard chipboard panel thickness 13 mm
- Frontal Laminate: Decorative Laminate
- Back Laminate: White Balancing Laminate or Decorative Laminate for double-sided
- Edge: ABS on all 4 sides by default
- Maximum Dimensions: 1280 mm - 4150 mm - Metals maximum length 3050 mm

INTEGRATED OR UNDER-TOP TUBS IN FENIX

The **FENIX KITCHEN SINKS** are inserted from below and fixed to the worktop in two different ways: Undermount (for HPL (and FENIX compact worktops) or flushmount (for HPL, FENIX and FENIX 1,2mm laminate worktops)

MOUNTING KEY POINTS:

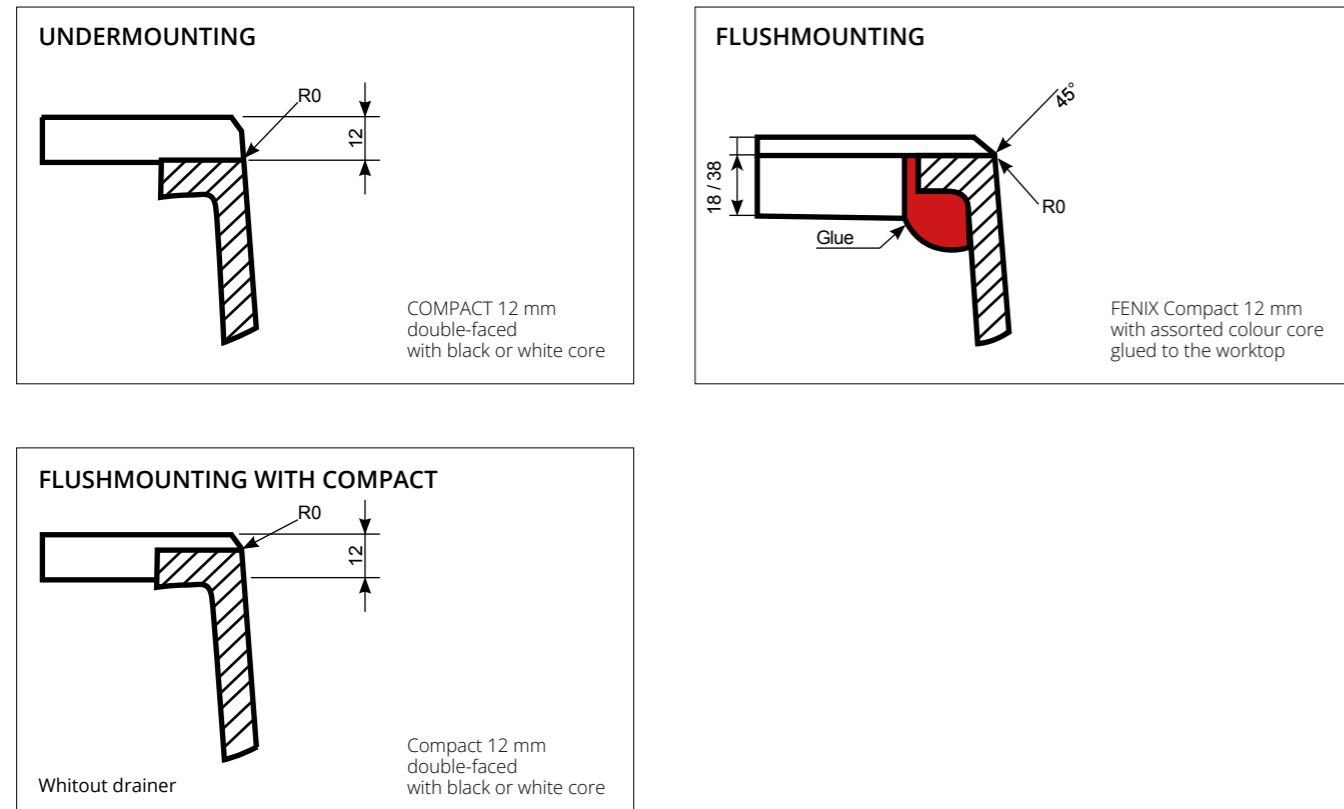

The FENIX INTEGRATED SOLUTIONS KITCHEN SINKS collection is an elegant and harmonious choice combining performance and aesthetics. Designed for sink production, this mix is made of ceramic nano-particles and six innovative acrylic resins. Its special composition makes the sink highly resistant to impacts and thermal stress. Its smooth surface allows quick water drip and creates a "lotus effect" that facilitates cleaning. The anti-UV treatment protects the sink from fading over time.

LARGE Flush tank

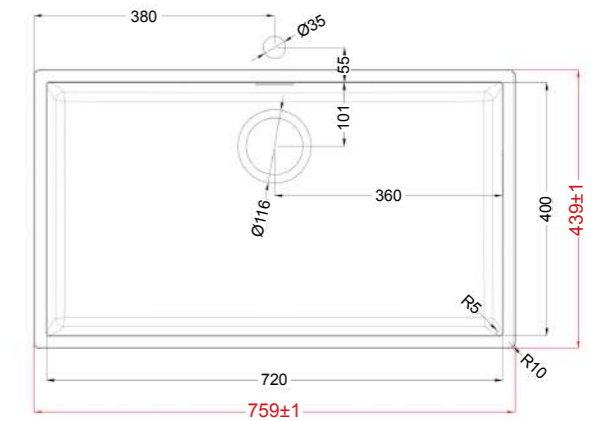
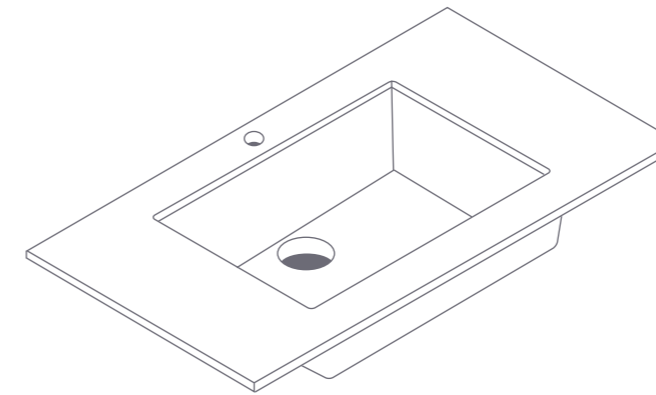

SINK KIT

- Recessed drain system
- Extra-compact rectangular overflow
- Siphon

DIMENSIONS

Tank 720 x 400 mm
 Min W. top dim. 800 mm

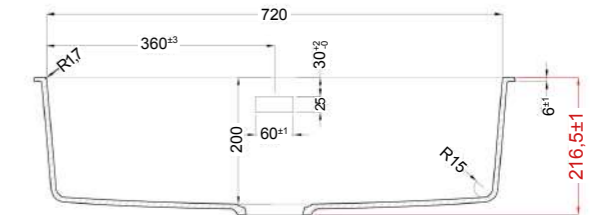

MEDIUM Flush tank

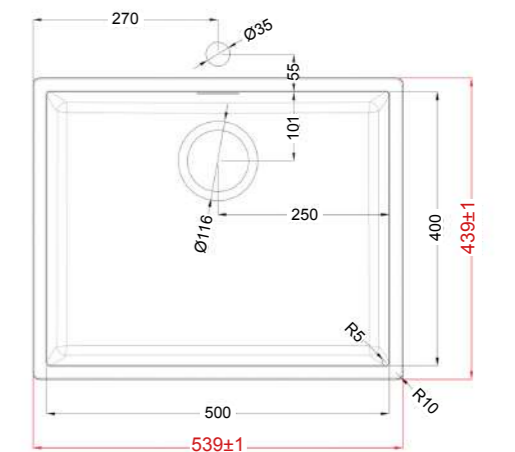
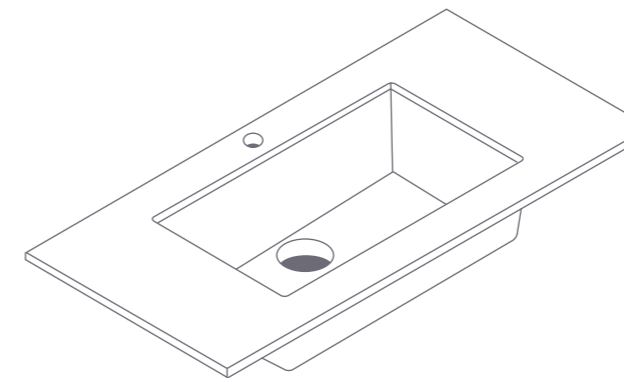

SINK KIT

- Recessed drain system
- Extra-compact rectangular overflow
- Siphon

DIMENSIONS

Tank 500 x 400 mm
 Min W. top dim. 600 mm

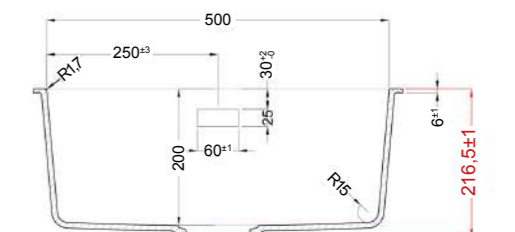

INTEGRATED OR UNDERMOUNTED ELLECI TANKS

The ELLECI KITCHEN SINKS are inserted from below and fixed to the worktop in two different ways: Undermount or flushmount.

MOUNTING KEY POINTS:

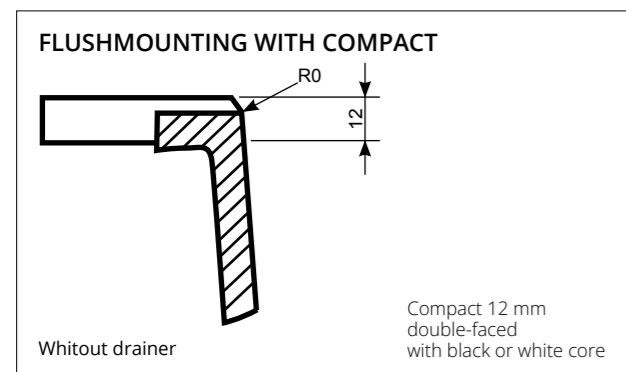
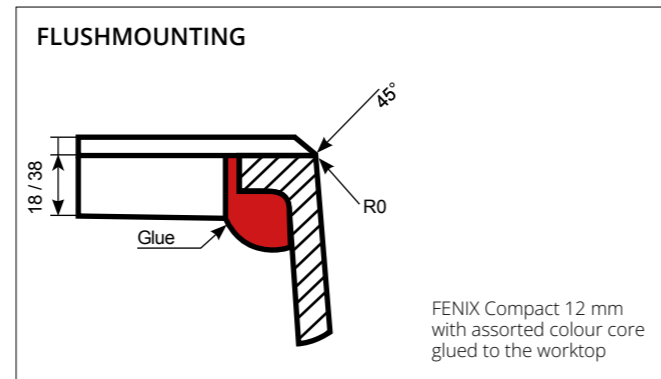
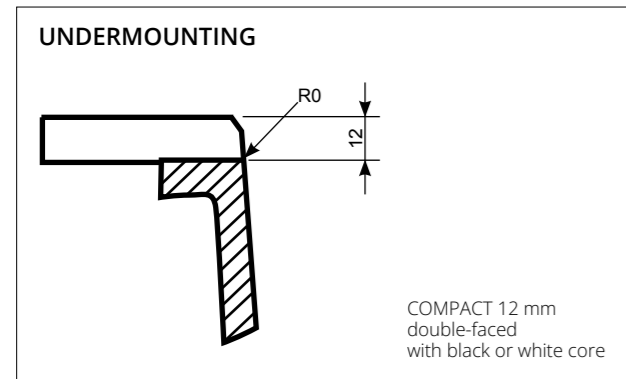

KERATEK PLUS is an innovative material, composed of natural stone, acrylic resin and ceramic nanoparticles. It is made using a new technology that compacts the surface to the maximum, making it resistant and giving it a high colour rendering. The Keratek Plus sink will therefore be smooth to the touch, making cleaning much easier. Thanks to this new technology, the quartz that is used can form stronger bonds with the six acrylic resins used in production, making the sink much more compact and smooth than the Granitek sink. A Keratek Plus sink will therefore have greater water repellency and durability and be even easier to clean.

LARGE Flush tank

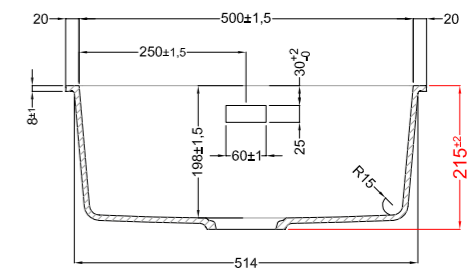
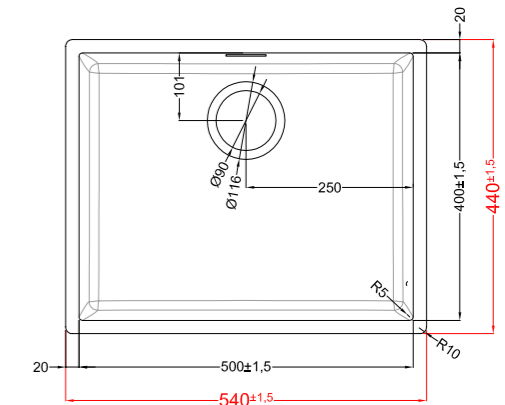
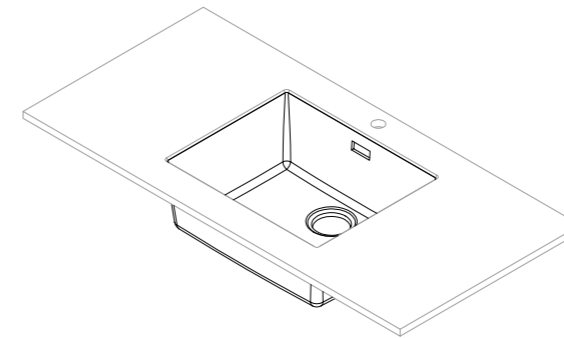

SINK KIT

Recessed drain system
Extra-compact rectangular overflow
Siphon

DIMENSIONS

Tank 500 x 400 x 198 mm
Min W. top dim. 600 mm

MEDIUM Flush tank

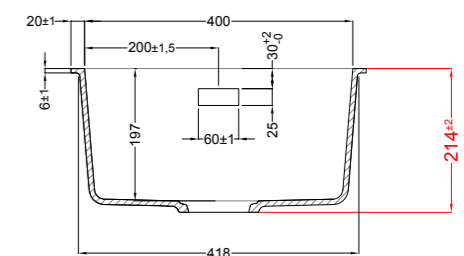
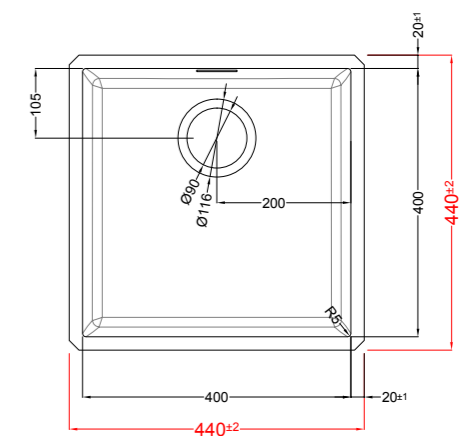
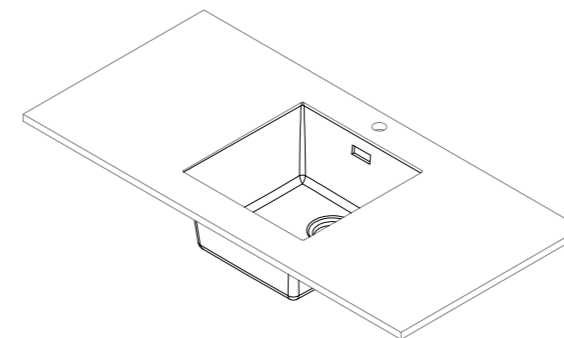

SINK KIT

Recessed drain system
Extra-compact rectangular overflow
Siphon

DIMENSIONS

Tank 400 x 400 x 197 mm
Min W. top dim. 600 mm

INTEGRATED STAINLESS STEEL TANKS

The only stainless steel sink that can be perfectly integrated in our worktops with HPL and FENIX laminates and FENIX Compact 1,2 mm. With its 30 years of experience in the design of kitchen sinks, EdgeSinks™ launches a new system that revolutionises the relationship between sink and worktop. The new EdgeSinks™ collection is the result of a technological research that has led to the development of a product that is innovative both aesthetically and functionally. Thanks to a special manufacture and integration method, we achieve a perfect continuity between worktop and sink, resulting in a tactile and elegant visual impact. The sinks are very thick and have an inner radius of approx. 15mm for precise cleaning. They are also available in most dimensions.

- Perfect integration with our laminates
- Highly hygienic
- No silicone
- Highly aesthetic
- Easy maintenance
- Corners with 15 mm radius
- Stainless steel 304, 1.2 mm thick

- Overflow
- Steel surface with brushed satin finish
- Functional flow lines
- Moulded resin edges machined 25 mm
- 90 mm wide drain

MOUNTING KEY POINTS:

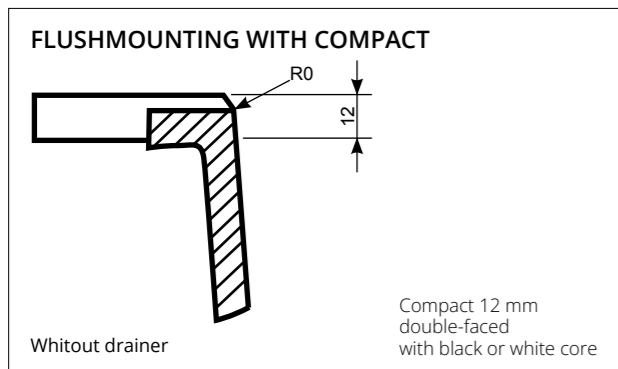
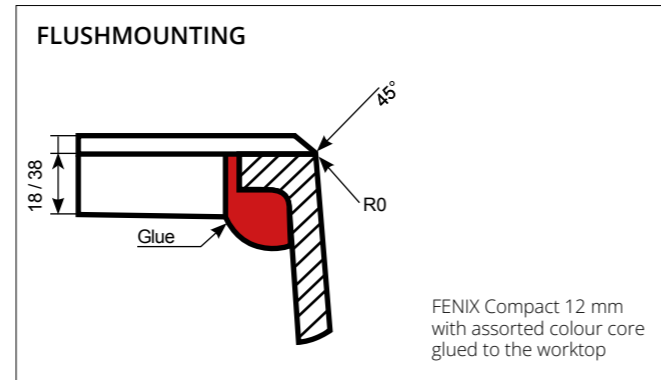
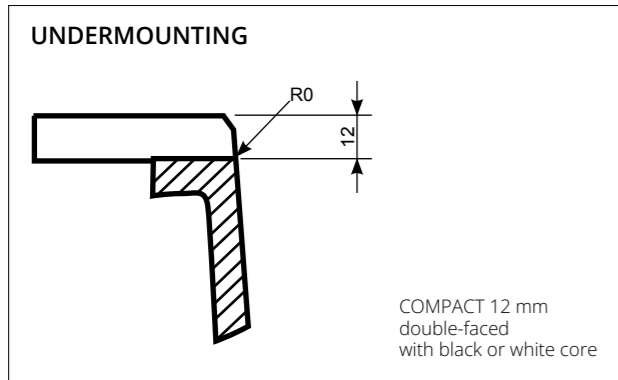

LARGE Flush tank

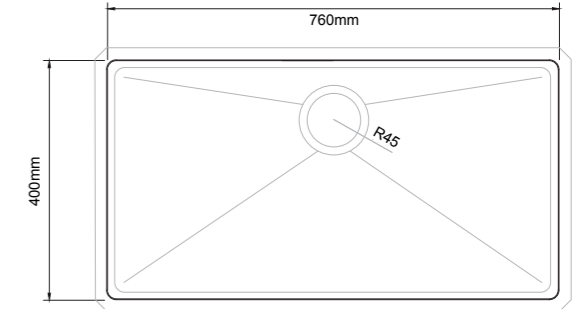
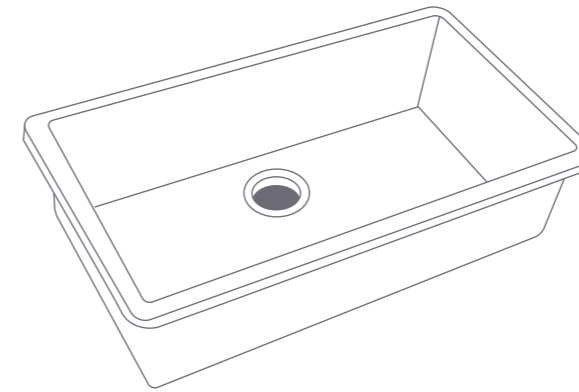

SINK KIT

Drain kit and overflow included

DIMENSIONS

Tank 760 x 400 x 200 mm
External dimensions of the basin 920 x 580 x 300 mm
Weight 7,9 kg

MEDIUM Flush tank

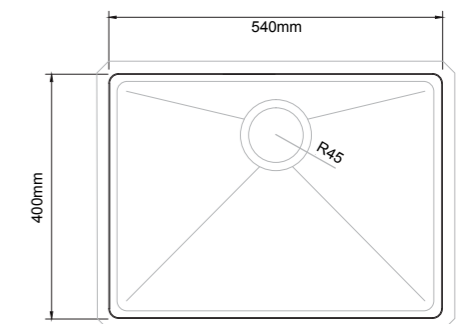
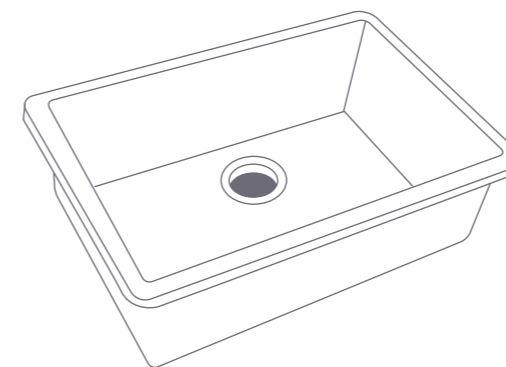

SINK KIT

Drain kit and overflow included

DIMENSIONS

Tank 540 x 400 x 200 mm
External dimensions of the basin 710 x 580 x 300 mm
Weight 7,9 kg

INTEGRATED TANKS IN COMPACT TOPSTARS

The compact laminate sink offers optimal integration with worktops, providing a robust and functional solution for demanding kitchen spaces. Made of high-density compact laminate, this sink effectively withstands mechanical stress and offers a surface that is impermeable to liquids and easy to clean. The compact laminate, characterised by its multilayer, high-pressure layered composition, gives the sink greater resistance to impacts and scratches. Its homogeneous surface guarantees maximum hygiene, meeting the rigorous demands of professional culinary environments. This technical solution combines durability and performance, offering an integrated solution for kitchen applications requiring structural strength and ease of maintenance.

MOUNTING KEY POINTS:

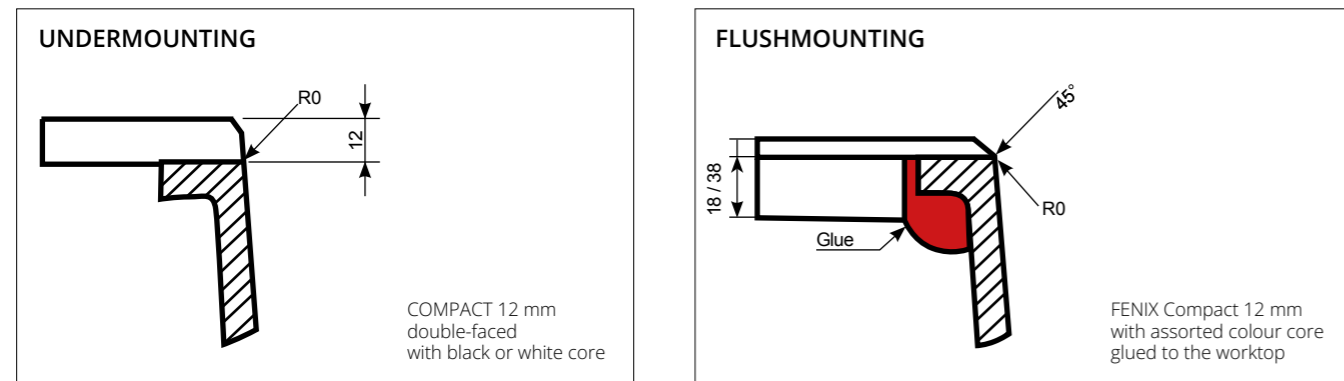

XXL Flush tank

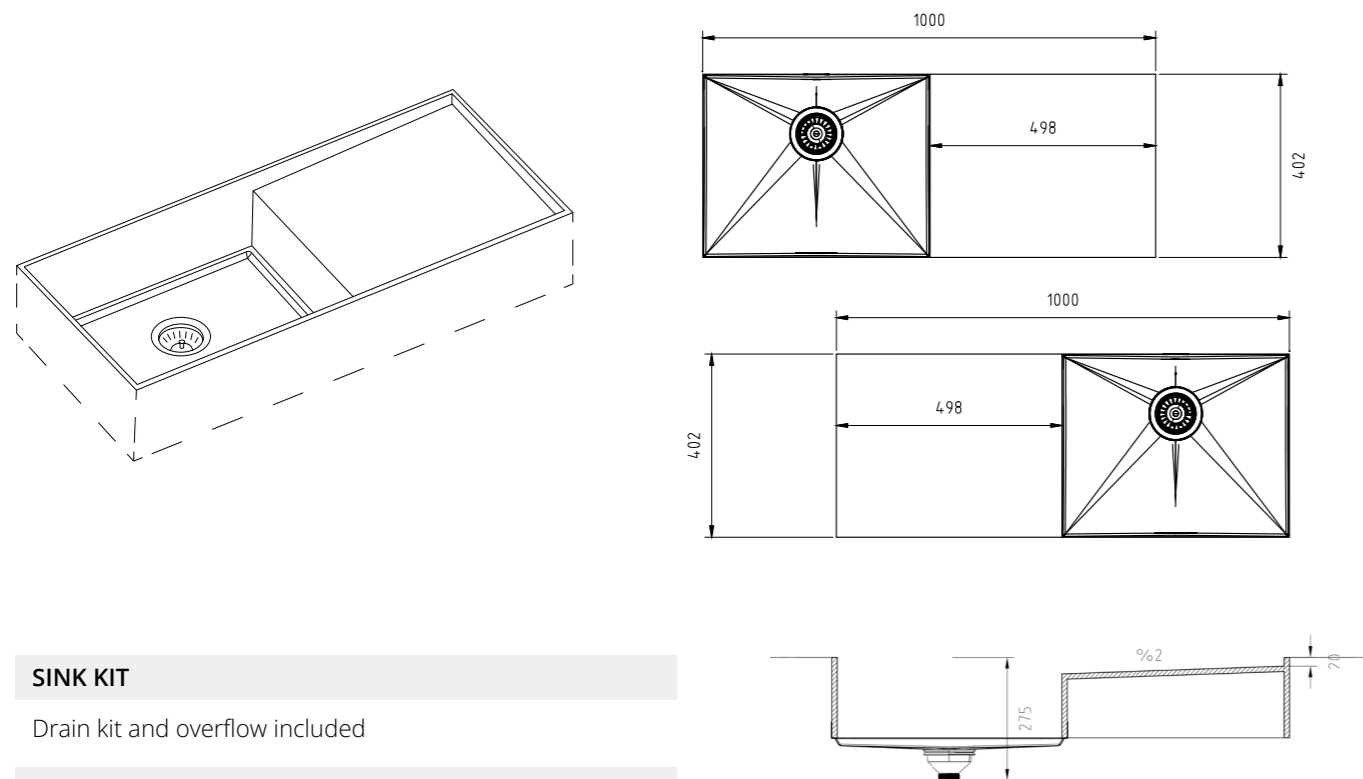

SINK KIT

Drain kit and overflow included

DIMENSIONS

Tank 1000 x 400 mm - Sink 500 x 400 mm

LARGE Flush tank



SINK KIT

Drain kit and overflow included

DIMENSIONS

Tank 710 x 400 mm

MEDIUM Flush tank

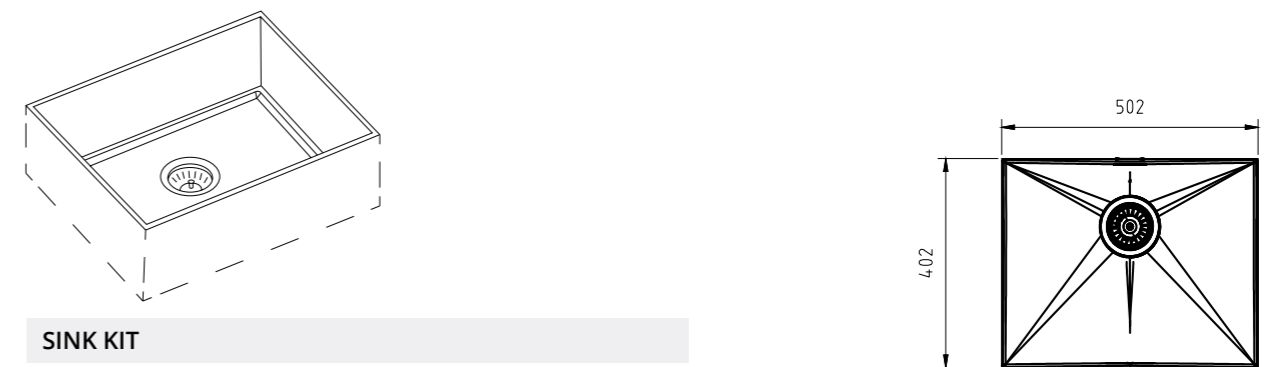

SINK KIT

Drain kit and overflow included

DIMENSIONS

Tank 500 x 400 mm

SMALL Flush tank

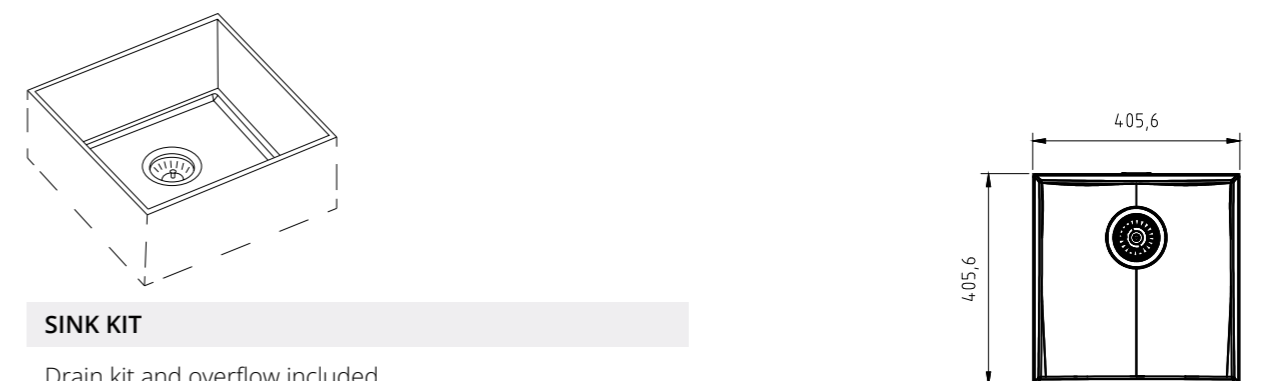

SINK KIT

Drain kit and overflow included

DIMENSIONS

Tank 400 x 400 mm

<p style="text-align: center;">QUADRA 1</p>	<p style="text-align: center;">QUADRA 2</p>
<p style="text-align: center;">QUADRA 3</p>	<p style="text-align: center;">QUADRA 4</p>
<p style="text-align: center;">MASTER</p> <p style="text-align: center;">MASTER 2BD MASTER 2BG</p>	

<p style="text-align: center;">MASTER</p> <p style="text-align: right;">MASTER BD MASTER BG</p>	
<p style="text-align: center;">KE 1</p>	<p style="text-align: center;">KE 2</p>
<p style="text-align: center;">KE 3</p>	<p style="text-align: center;">S4001</p>

<p style="text-align: center;">DELTA</p>	<p style="text-align: center;">DELTA PLUS</p>
<p style="text-align: center;">LORENZO</p>	<p style="text-align: center;">ARSENIO</p>
<p style="text-align: center;">FLAT</p>	

<p style="text-align: center;">NYC</p>	<p style="text-align: center;">OMEGA</p>
<p style="text-align: center;">OMEGA PLUS</p>	

INTEGRATED OR UNDERMOUNTED BATHROOM SINKS IN FENIX

A collection of Washbasins designed to match vanity tops made of FENIX. An integrated solution combining FENIX innovative materials with a selection of washbasins made of an original «matt composite material» that suits FENIX look and feel.

MOUNTING KEY POINTS:

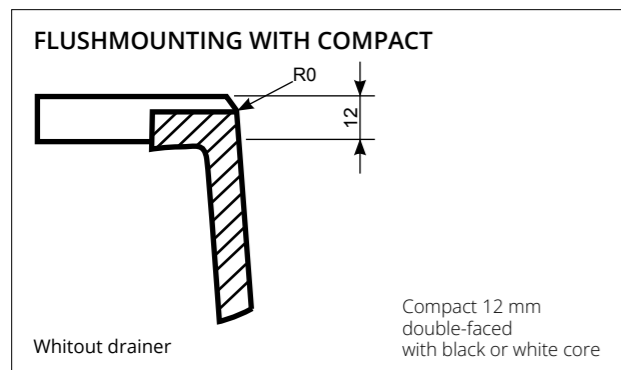
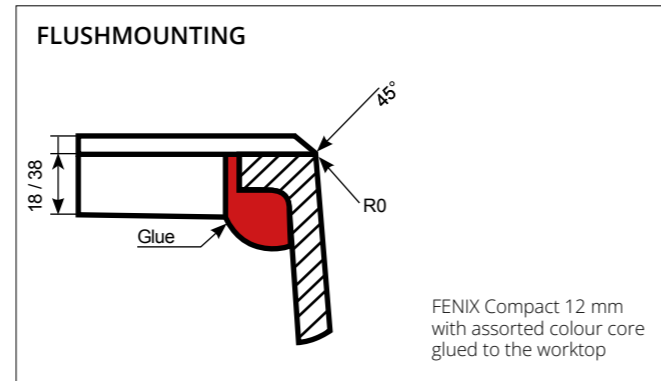
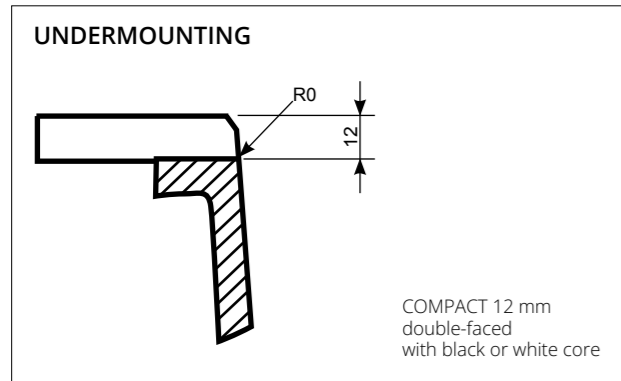

LARGE

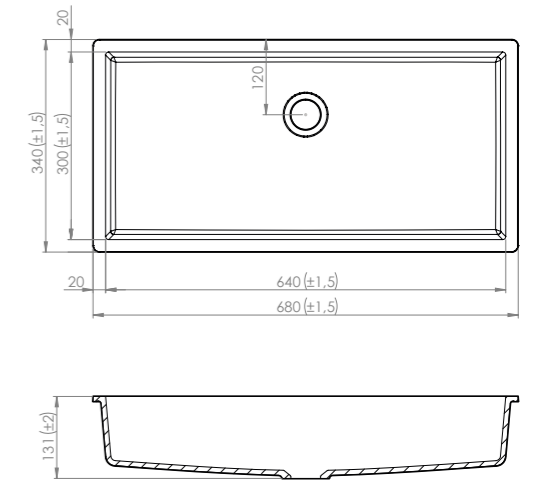
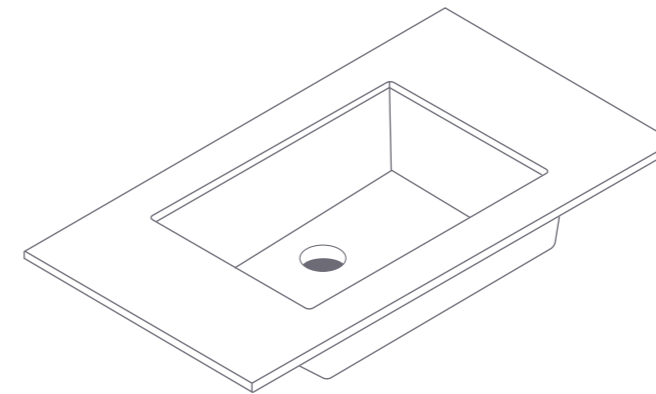

DIMENSIONS

Tank 640 x 300 mm

MEDIUM

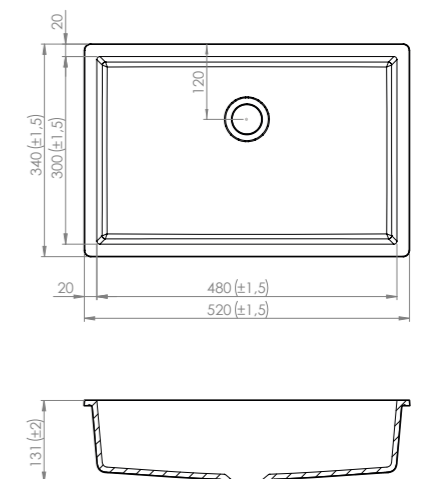
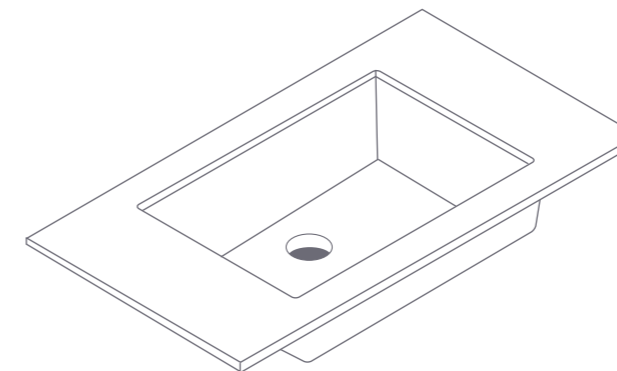

DIMENSIONS

Tank 480 x 300 mm

RECCOMENDEATIONS FOR INSTALLING THE COMPACT

GLUING WORKTOPS ONTO BASES

During the gluing of the compact onto bases, it is recommended to use PU (Polyurethane) glue, applied in beads. Ensure that the surfaces are completely free of dust and degreased before application. On a base with a ceiling, space the beads 30 cm apart discontinuously to allow air circulation and keep them 10 mm away from the edge. For bases without a ceiling, position the beads discontinuously and keep them 10 mm away from the edge. To avoid the flexion of the countertop, it is essential to provide at least four support surfaces on the base (front, back, left, and right) and install support bars on the sides of the openings. A maximum snack countertop of 350 mm (overhang into the void) is acceptable.

Furniture with ceiling

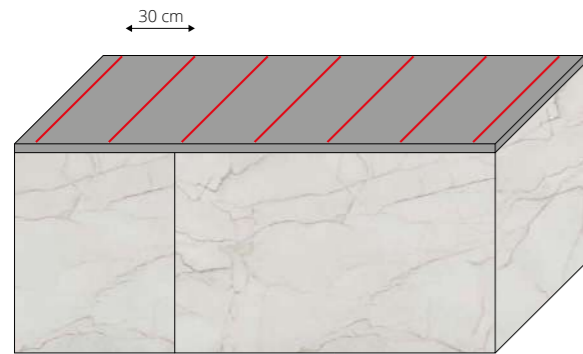

— Adhesive strips

Furniture without ceiling

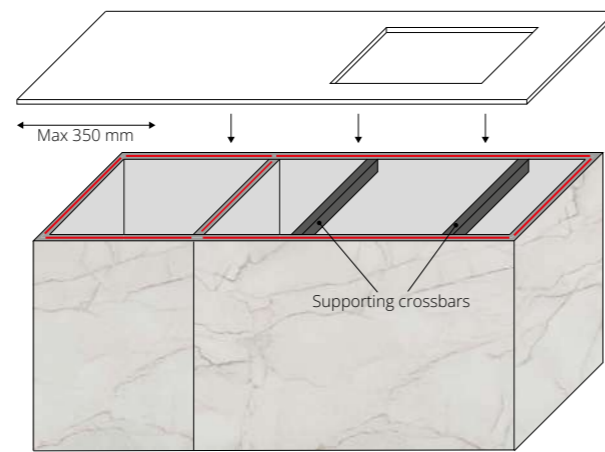
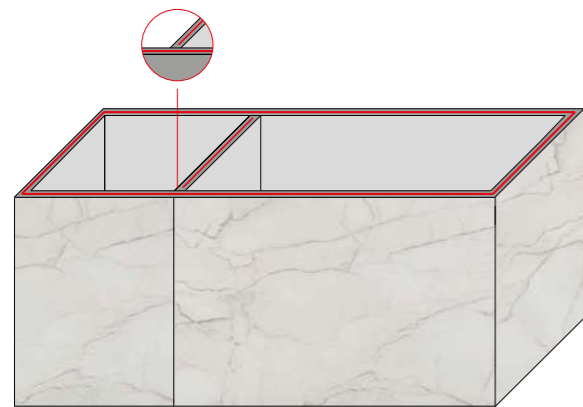

WALL PANEL GLUING

Gluing the back panels requires the application of beads of polyurethane adhesive sealant, with intervals of 30 cm between them. These discontinuous beads, to promote air circulation, should be 10 mm away from the edge, following the same principle as gluing onto a base with a ceiling. It is essential to avoid depositing glue dots. To prevent any sealing issues, the joint between the back panel and the countertop must be isolated with a silicone seal. Note that use behind a gas cooker is not recommended.

VENTILATION

Ensuring uniform ventilation on both sides of the panel is crucial to maintain balance in terms of temperature and humidity. It is therefore essential to strictly adhere to the gluing rules described in the document, especially by applying glue in discontinuous beads.

EXPANSION

Dimensional variations depend on the panel's orientation (length or width). It is imperative to consider these variations and never block the panel. For installation between two fixed walls, provide a space of around 3-5 mm on each side, which can be concealed by return claddings.

ISLAND / TABLE

Opting for installation on a supporting structure minimizes the risks of warping, ensuring the stability of the island or table.

SHELVES

SHELVES 39 mm 59 mm - MAXIMUM WEIGHT 15 KG / FIXING
MINIMUM SHELF DEPTH 200 MM MAXIMUM 350 MM

ADJUSTMENT OF SHELF SUPPORTS:

The fixing support provides the possibility of adjusting the shelf on three independent axes: vertical, lateral, and inclination.

Vertical Adjustment

Adjust the shelf height by unscrewing the fixing screws, moving the fixing supports, then tighten the screws to secure the position.

Loosening the fixing screws.

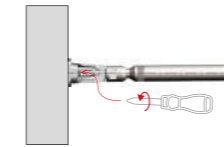

Align the supports vertically.

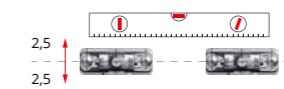

Tighten the fixing screws.

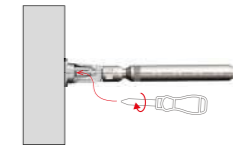

Lateral Adjustment

By partially inserting the shelf, the support rods can be moved laterally. Align the supports vertically by adjusting them before fixing the shelf in place.

Tilt the shelf to match the support bar and partially insert it into the grooves.

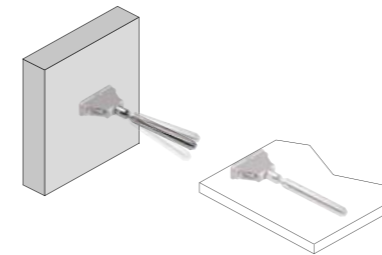

Partially insert the shelf.

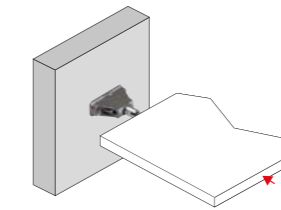

Adjust the shelf horizontally.

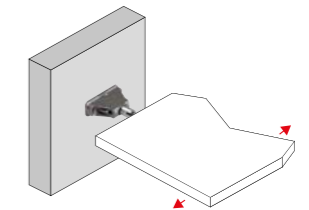

Tilt Adjustment

Once the shelf is partially inserted, adjust the angle by aligning the support bar with the grooves. Use a 10 mm flat wrench to turn the support bar clockwise and adjust the angle from front to back.

Rotate the support rod clockwise using a 10 mm flat wrench to adjust the shelf angle front to back.

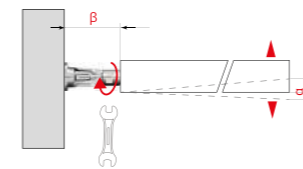

Tighten the locking screw to secure the rod.

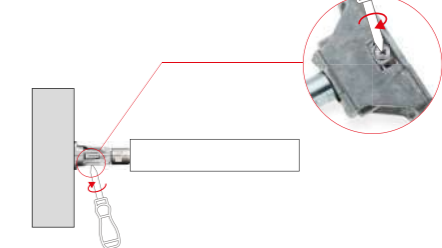

WALL FIXING: The fixing bracket is provided already assembled and ready for installation. Simply attach it to the wall with 2 D5 screws and corresponding plugs. We recommend mounting the shelves on a suitable support (particleboard, bricks, concrete, wood, ...).

Mounting using only the fixing bracket:

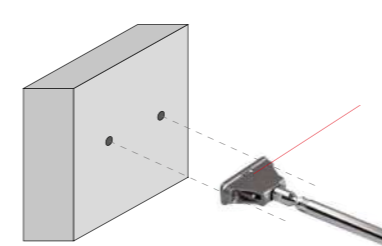

The fixing must be installed with the label "TOP ALTO" facing upwards.

USE AND MAINTENANCE OF WORKTOPS

TOPSTAR worktops are designed to require minimal maintenance. They can be easily cleaned with a soapy sponge or a damp cloth. The laminate or compact used in these countertops are ideal materials to withstand common household activities such as water or food splashes. The laminates and compacts comply with EN438 standards, but it is essential to follow some recommendations to preserve the original appearance of the worktop.

RECOMMENDATIONS FOR USAGE

- Absolutely avoid cutting directly on the surface of the worktop. Always use a cutting board or chopping board.
- Never place hot dishes directly on the worktop. Use a trivet, such as stainless steel bars for Compact worktops.
- Do not leave hot appliances, such as a coffee maker, on for several hours directly on the worktop.

STAINS AND CLEANING

- Stains from red wine, tea, coffee, fruit juices, or certain chemicals should be promptly cleaned to avoid any surface alteration.
- Avoid letting water pool on the worktop, especially in sensitive areas and those in contact with backsplashes.

GLOSSY WORKTOPS

- Glossy worktops require special attention. Avoid sliding dishes or kitchen utensils to prevent scratches on the laminate.
- Textured finishes tolerate stress better than smooth, matte, or glossy finishes.

STORAGE OF WORKTOPS

- To maintain optimal flatness, it is strongly recommended not to lean the worktops and backsplashes against a wall. Horizontal storage is recommended, without direct contact with the floor.

GENERAL MAINTENANCE

- Daily maintenance is easily done with a soapy sponge or a soft cloth.
- Never use steel wool, abrasive sponges, metal brushes, or harsh abrasives.
- For stubborn stains, start by using a magic sponge. If that's not sufficient, use an organic solvent, rinse, and dry with a microfiber cloth.
- Take precautions when using organic solvents: ventilate the area, wear rubber gloves and protective eyewear, work away from heat sources.

PRODUCTS TO AVOID

- Liquid or powdered abrasive products.
- Wax-based products.
- Bleaching products (bleach).
- Chemical detergents containing strong bases or strong acids (limescale remover, hydrochloric acid, unlocking agents, silverware cleaner...).

GENERAL CONDITIONS OF SALE

I - GENERAL CLAUSES

Sales are subject to these general conditions that prevail over any other condition of purchase, unless a formal derogation is accepted by the seller. Consequently, no special conditions may prevail over the general conditions of sale, unless it is formally accepted by the seller in writing.

In the absence of express acceptance, any conflicting condition set forth by the buyer shall therefore be unenforceable against the seller, regardless of when it may have been brought to its attention.

II - ORDER ACCEPTANCE

Orders are deemed to be final only when they have been confirmed in writing and expressly accepted by the seller.

III - ORDER MODIFICATION

Any order modification or termination requested by the buyer can only be taken into consideration if it is received in writing and within a maximum of 48 hours after receipt of the Acknowledgement of Order.

If the seller does not accept such modification or termination, the advance payments at the order will not be returned.

IV - DELIVERIES

Delivery times are only given as an indication. Possible delays do not entitle the buyer to request the order termination, to refuse the product or to claim damages.

The products are deliverable carriage paid to the place agreed as per document A1 «Account Opening»

V - RETENTION OF TITLE

The seller retains ownership of the goods sold until actual payment of the full principal price and ancillaries.

The risk in the goods custody shall pass to the buyer on the day of its availability. In the event of partial or total non-payment, the seller may request either the return of the goods at the buyer's expense, or the immediate payment of all sums due.

VI - WARRANTY

The products being sold are for strictly domestic use and are intended to equip individual houses or multi-residential buildings. They must be installed in closed rooms with sufficient ventilation and heating to prevent deformation and to ensure humidity and hygrometry satisfactory levels. Such installation must be carried out according to generally-accepted practices.

The warranty does not apply if the products are installed or used for a purpose other than the one for which they are intended.

It is also void if the products are modified or subject to repair or maintenance by persons not being authorised by the seller. Finally, it is not applicable in the event of a defect in the design of the assembly into which the products are fitted or of erroneous measurements by the purchasing installer. This warranty, which excludes any liability other than the one relating to the products, is limited to the replacement of defective products or parts (or even the supply of products or parts for the same use if it is impossible to replace them with identical products or parts) or the reimbursement of their sale price, excluding the compensation of any other damage and the coverage of labour costs.

The installer may only benefit from the warranty if he/she notifies the seller by registered letter with acknowledgement of receipt within three months of delivery. Except with the agreement of the seller, no product or goods will be taken back.

The warranty for apparent defects in the products or for defects in conformity with the order or the dispatch note shall only apply if a complaint is made in writing by the seller within eight days of delivery of the products, without prejudice to the measures the buyer needs to take with regard to the carrier.

It will be up to the purchasing installer to prove evidence of the defects or anomalies observed and he/she will have to let the seller or their representatives establish their actual presence and possibly remedy them.

The installer will refrain from taking actions himself/herself or having a third party take actions to this end. The seller shall not be bound by

any obligation beyond the eight-day period.

The buyer may only return the products after prior written agreement from the seller. The buyer shall keep them at their premises without being able to claim any compensation and until receipt of said agreement.

Under no circumstances can the buyer return the products to the seller with carriage forward, the transport costs and all other return costs being the exclusive responsibility of the buyer, whatever the reason for the return.

VII - DAMAGED OR MISSING PRODUCTS

Our goods are sent at the recipient's risk, even if free on board.

The buyer must express their reservations precisely on the delivery note, in agreement with the carrier.

The buyer must confirm any claim by registered letter with acknowledgement of receipt addressed to the carrier within three working days following delivery and send a copy of such claim to the seller.

After the date of dispatch of the registered letter the damaged products must be kept at the disposal of the carrier, the expert and relevant insurance company.

Whatever the reason for the dispute, the products must under no circumstances be returned to the seller without the latter's prior agreement.

VIII - CONDITIONS OF SALE

Obtaining negative information about the buyer (drafts that remain unpaid, payment incidents, protests, etc.) authorises the seller to refuse any order or to request an advance of funds or to apply the buyer different payment terms from those applied to other customers.

IX - INVOICING

The prices invoiced are those of the price list in force at the time of delivery, it being understood that these prices will take into account any changes in prices as well as any turnover taxes that may be applicable at the time of delivery.

X - PAYMENT

Invoices are payable within 20 days of invoicing or in cash, unless otherwise agreed.

XI - LATE OR NON-PAYMENT

Any delay in payment shall automatically and without formal notice result in the payment of interest on arrears equal to at least 3 times the legal interest rate.

For payment in instalments, failure to pay one of them on the due date will result in the entire debt becoming immediately payable, without formal notice.

XII - JURISDICTION AND APPLICABLE LAW

For any dispute that may arise between the parties regarding the establishment, execution and interpretation of the sales contract, the Court of Pesaro (PU) Italy, shall have sole jurisdiction, which will decide in accordance with Italian law.

Organization certified with Quality Management System
UNI EN ISO9001: 2015 par CSI Spa

Art direction | Graphic Design | Image

LIFECOMUNICA

Colour Separation
Print

LaserComunicazione
Gruppo Leardini
